

2.2.1. PAL-VF

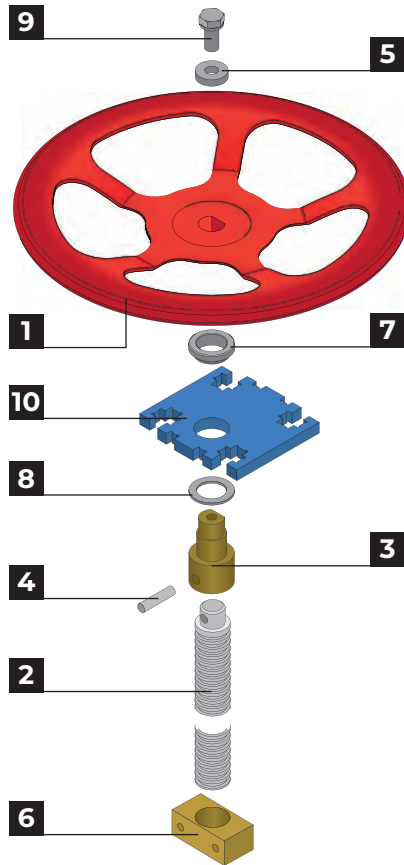

VF. Handwheel with non-rising stem

Made from DN50 to DN600. For other diameters, consult our Technical Department.

Description	Material	Unit
1 Handwheel	Steel	1
2 Stem	AISI-303	1
3 End-shaft bushing	Bichrom. F-114	1
4 Elastic pin	Steel	1
5 Washer	Steel	1
6 Nut	Brass	1
7 Bearing	POM	1
8 Washer	POM	1
9 Screw	Steel	1
10 Support case	Steel	1

*Other materials available on request.

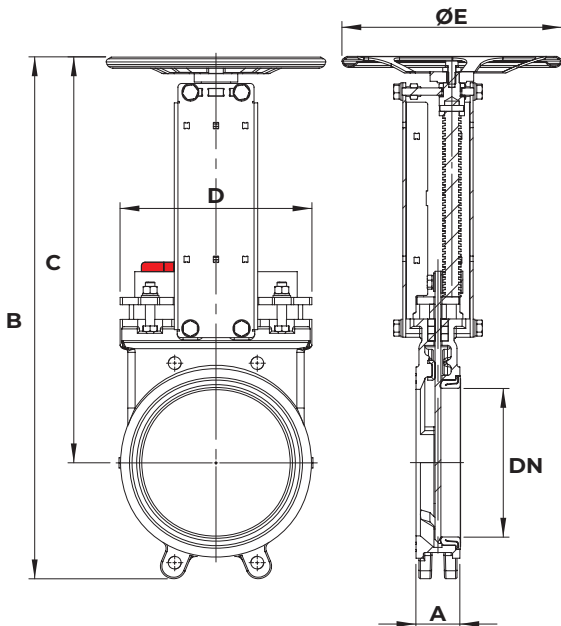

DN	A	B	C	D	ØE	Weight	Ps
50	40	400	340	145	200	7	10
65	40	411	346	160	200	7	10
80	50	456	368	172	200	8	10
100	50	506	403	194	200	10	10
125	50	546	429	184	250	13	10
150	60	602	474	211	250	16	10
200	60	713	554	262	300	25	10
250	70	833	638	316	300	30	10
300	70	971	740	375	300	45	6
350	96	1,067	856	423	400	66	6
400	100	1,232	979	507	400	105	6
450	100	1,373	1,084	579	500	135	5
500	110	1,553	1,207	618	500	179	4
600	110	1,824	1,452	743	500	243	3

Other diameters available on request

Assembly between PN10/Class150 flanges
DN Nominal diameter

Dimensions in mm
ØE Wheel diameter

Weight in kg
Ps Nominal pressure in bar